



LIGITEK

LIGITEK ELECTRONICS CO.,LTD.  
Property of Ligitek Only

---

3W Power Light LED

LGFLV-313E1

# DATA SHEET

DOC. NO : QW0905-LGFLV-313E1#

REV. : A

DATE : 22 - Jun - 2009

## High Power Product Model Designation System

LG   F   L   V - 3   1   3   E   1  
 X1   X2   X3   X4   X5   X6   X7   X8   X9

X1	X2	X3	X4	X5
Title	Process	Lens Type	Emitting Color	Leadframe Type
LG:Ligitek	F:Ir-Reflow	L:Lambertian	V:Warm White N:Neutral White W:Cool White	3:Round Type 5:Rectangle Type

X6	X7	X8	X9
Modification	Power	Module	Luminous Flux Modification
	1: 1W 3: 3W	E: Emitter H: Star	

## Features

- \*. High Flux per LED
- \*. Very long operating life.
- \*. Available in White.
- \*. More Energy Efficient than Incandescent and most Halogen lamps.
- \*. Low voltage DC operated..
- \*. Cool beam, safe to the touch.
- \*. Instant light(less than 100 ns).
- \*. Fully dimmable.
- \*. No UV.
- \*. Superior ESD protection..
- \*. Reflow process compatible

## Typical Applications

- \*. Reading Light (car,bus,aircraft)
- \*. Portable(flashlight,bicycle).
- \*. LCD Backlights / Light Guides.
- \*. Automotive Exterior (Stop-Tail-Turn,CHMSL,Mirror Side Repeat).
- \*. Commercial and Residential Architectural lighting.
- \*. Mini-accent / Uplighters / Downlighters / Orientation lighting
- \*. Fiber Optic Alternative / Decorative / Entertainment lighting.
- \*. Security / Garden lighting.
- \*. Cove / Undersheff / Task lighting.
- \*. Traffic signaling / Beacons / Rail crossing and Wayside lighting.
- \*. Decorative.
- \*. Sign and channel Letter.

## Dimension

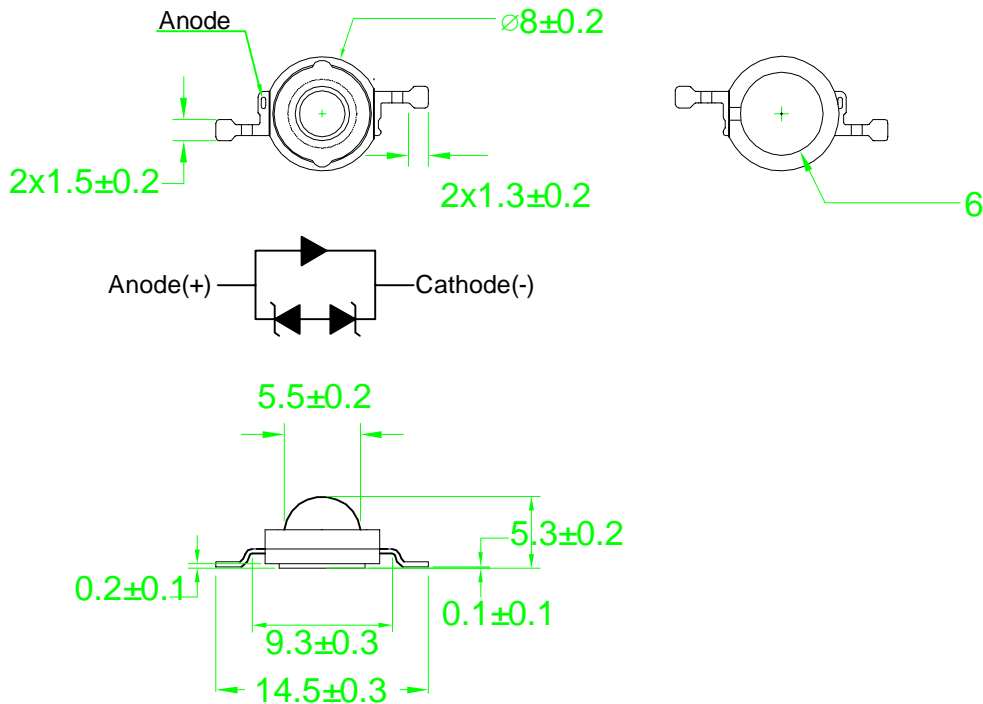

- Note:1. All dimension are in millimeter.  
 2. The anode side of the device is denoted by a hole in the lead frame.  
 3. It is strongly recommended to apply on electrically isolated heat conducting film between the slug and contact surfaces.  
 4. Drawings are not to scale.  
 5. All dimensions without tolerances are for reference only.



## Absolute Maximum Ratings at Ta=25

Parameter	Symbol	Ratings	UNIT
		Warm White	
DC Forward Current	IF	700	mA
Power Dissipation	PD	2.8	W
Peak pulse current Duty 1/10@10KHz	IFP	1000	mA
LED junction Temperature	Tj	125	
Reverse Current(VR=5V)	Ir	100	μ A
ESD Sensitivity	VB	±4000	V
Storage Temperature	Tstg	-40 ~ +120	
Operating Temperature	Topr	-40 ~ +100	
Soldering Temperature	Tp	260	
Manual Soldering Time at 260°C(Max)	Tsol	5	seconds

**NOTE:**

1. Proper current derating must be observed to maintain temperature below the maximum.
2. LEDS are not designed to be driven in reverse bias.

## Luminous Flux Characteristics at 700mA (Ratings At 25 Ambient)

Radiation Pattern	PART NO	Emission Color	Luminous Flux @700mA(Im)			Units
			Min.	Typ.	Max.	
Lambertian	LGFLV-313E1	Warm White	113.6	145	----	Im

**Note :**

1. White emitters are built with InGaN.
2. Flux and power is measured with an accuracy of ±10%



### . Forward Voltage Characteristics at 700mA

(Ratings At 25 Ambient)

Radiation Pattern	PART NO	Emission Color	Vf			Units
			Min.	Typ.	Max.	
Lambertian	LGFLV-313E1	Warm White	3.0	3.5	4.0	V

Note : Forward Voltage is measured with an accuracy of ±0.1V

### . Color Temperature Characteristics at 700mA

(Ratings At 25 Ambient)

Radiation Pattern	PART NO	Emission Color	CCT			Units
			Min.	Typ.	Max.	
Lambertian	LGFLV-313E1	Warm White	2670	----	3800	K

Note : CCT±5% tester tolerance.

### . Temperature Coefficient Of Forward Voltage&Thermal Resistance Junction To Board Characteristics at 700mA

(Ratings At 25 Ambient)

Radiation Pattern	PART NO	Emission Color	$\Delta Vf/\Delta T$		Rth,j-B	
			Typ.	Units	Typ.	Units
Lambertian	LGFLV-313E1	Warm White	-2	mV/°C	18	°C/W

### . Emission Angle Characteristics at 700mA

(Ratings At 25 Ambient)

PART NO	Emission Color	Lambertian	Units
LGFLV-313E1	Warm White	140	Degrees



### Brightness Code For High Power LED

Group	Luminous flux(lm)	
	Min	Max
F26	113.6	147.7
F27-1	147.7	170

Note : Flux is measured with an accuracy of  $\pm 10\%$

### White Binning Structure Graphical Representation

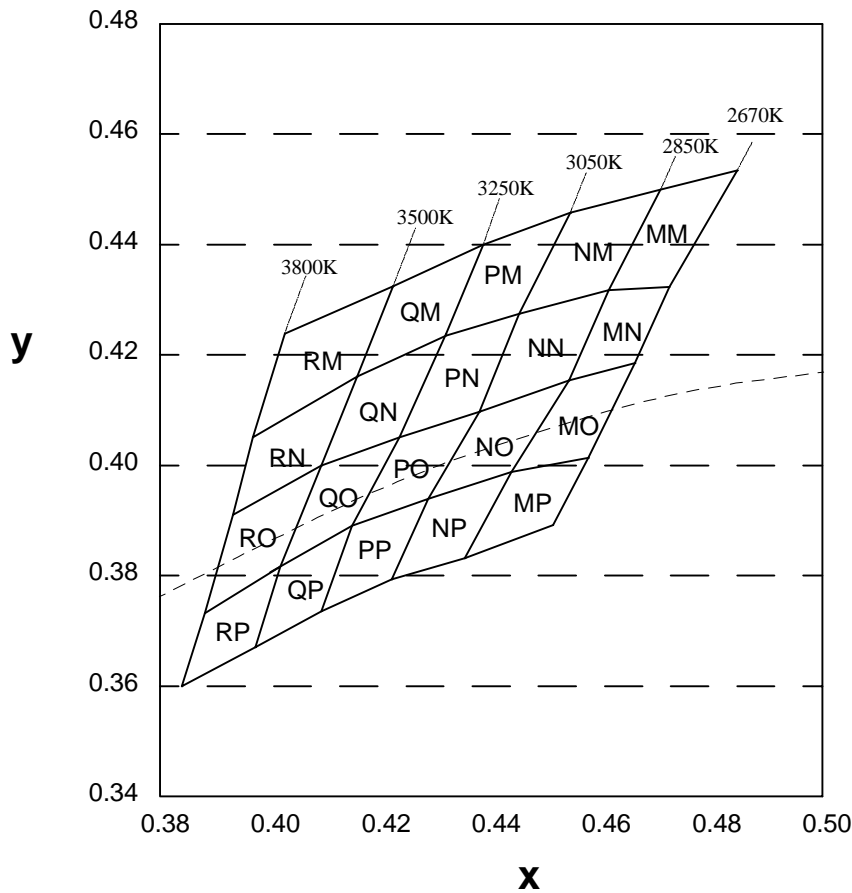



Color Bins  
White Bin Structure  
20 color bins, CCT range 3800K to 2670K

Bin Code	x	y	Typ. CCT (K)
MO	0.453	0.416	2760
	0.444	0.399	
	0.458	0.403	
	0.467	0.420	
MN	0.461	0.433	2760
	0.453	0.416	
	0.467	0.420	
	0.477	0.437	
MP	0.458	0.403	2760
	0.444	0.399	
	0.436	0.384	
	0.449	0.388	
MM	0.471	0.451	2760
	0.461	0.433	
	0.477	0.437	
	0.487	0.454	
NO	0.438	0.412	2950
	0.429	0.394	
	0.444	0.399	
	0.453	0.416	
NN	0.446	0.429	2950
	0.438	0.412	
	0.453	0.416	
	0.461	0.433	
NP	0.444	0.399	2950
	0.429	0.394	
	0.422	0.379	
	0.436	0.384	
NM	0.454	0.446	2950
	0.446	0.429	
	0.461	0.433	
	0.471	0.451	
PO	0.424	0.406	3150
	0.416	0.389	
	0.429	0.394	
	0.438	0.412	
PN	0.431	0.423	3150
	0.424	0.407	
	0.438	0.412	
	0.446	0.429	
PP	0.429	0.394	3150
	0.416	0.389	
	0.410	0.374	
	0.422	0.379	
PM	0.438	0.440	3150
	0.431	0.423	
	0.446	0.429	
	0.454	0.446	
QO	0.409	0.400	3375
	0.402	0.382	
	0.416	0.389	
	0.424	0.406	
QN	0.415	0.416	3375
	0.409	0.400	
	0.424	0.407	
	0.431	0.423	
QP	0.416	0.389	3375
	0.402	0.382	
	0.397	0.367	
	0.410	0.374	
QM	0.421	0.433	3375
	0.415	0.416	
	0.431	0.423	
	0.438	0.440	
RO	0.392	0.391	3650
	0.387	0.374	
	0.402	0.382	
	0.409	0.400	
RN	0.415	0.416	3650
	0.409	0.400	
	0.392	0.391	
	0.396	0.404	
RP	0.387	0.374	3650
	0.383	0.360	
	0.397	0.367	
	0.402	0.382	
RM	0.421	0.433	3650
	0.415	0.416	
	0.396	0.404	
	0.402	0.423	

NOTE: Tolerance on each color bin(x,y)is ±0.01



## Recommended Solder Pad Design

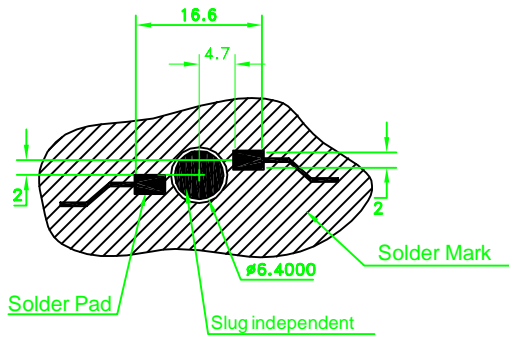

NOTE:

1. All dimensions are in mm.
2. The drawings are not to scale.
3. Solder pad can't be connected to slug.





## Recommended Profile for Reflow Soldering

The following reflow soldering profiles are provided for reference. Ligitek recommends that users follow the recommended soldering profile provided by the manufacturer of the solder paste used.

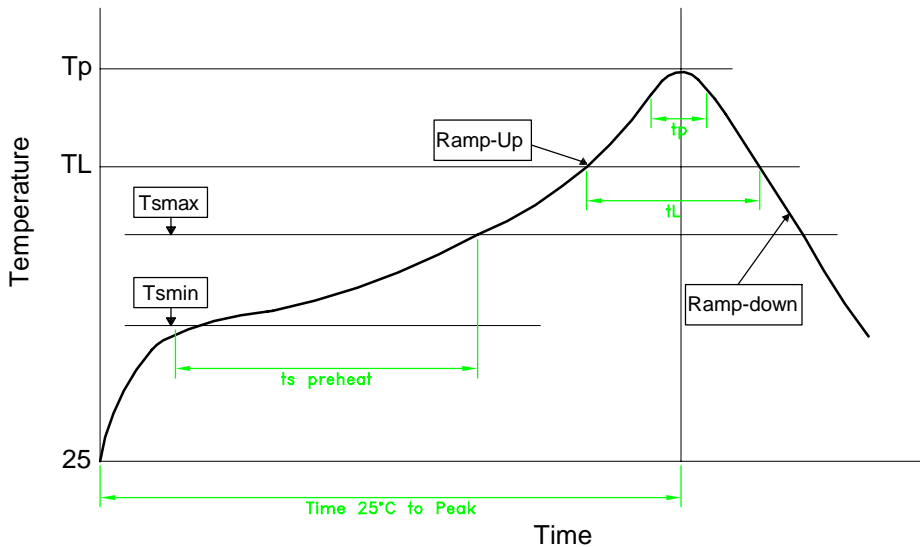

profile Feature	Pb-Free Assembly
Average Ramp-Up Rate( $T_{smax}$ to $T_p$ )	3° C/second max
Preheat Temperature Min( $T_{smin}$ )	150° C
Preheat Temperature Max( $T_{smax}$ )	200° C
Preheat Time( $t_{smin}$ to $t_{smax}$ )	60-120 seconds
Temperature( $T_L$ )	217° C
Time Maintained Above Temperature ( $T_L$ )	60-150 seconds
Peak/Classification Temperature( $T_p$ )	260° C
Time Within 5° C of Actual Peak Temperature( $t_p$ )	20-40 seconds
Ramp-Down Rate	6° C/second max
Time 25° C to Peak Temperature	8 minutes max



Fig.1 Forward current vs. Forward Voltage

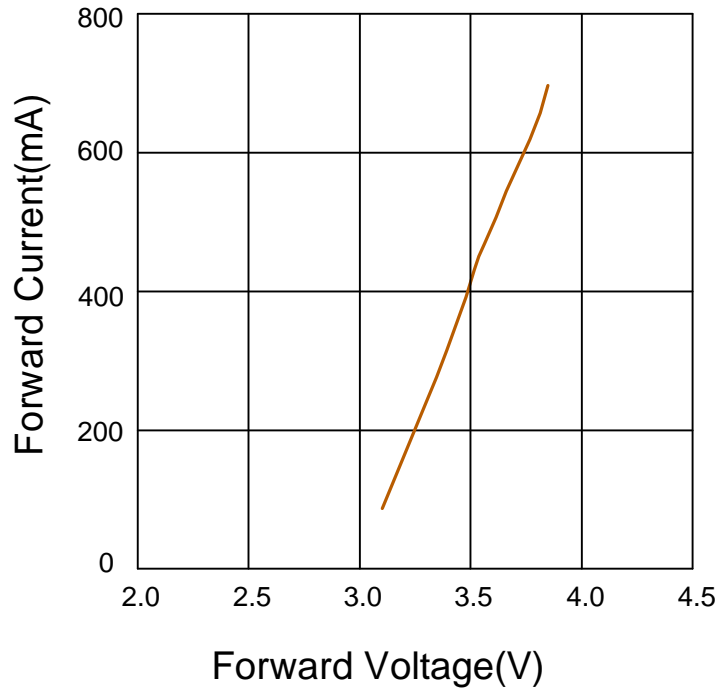

Fig.2 Operating current vs. Ambient Temperature

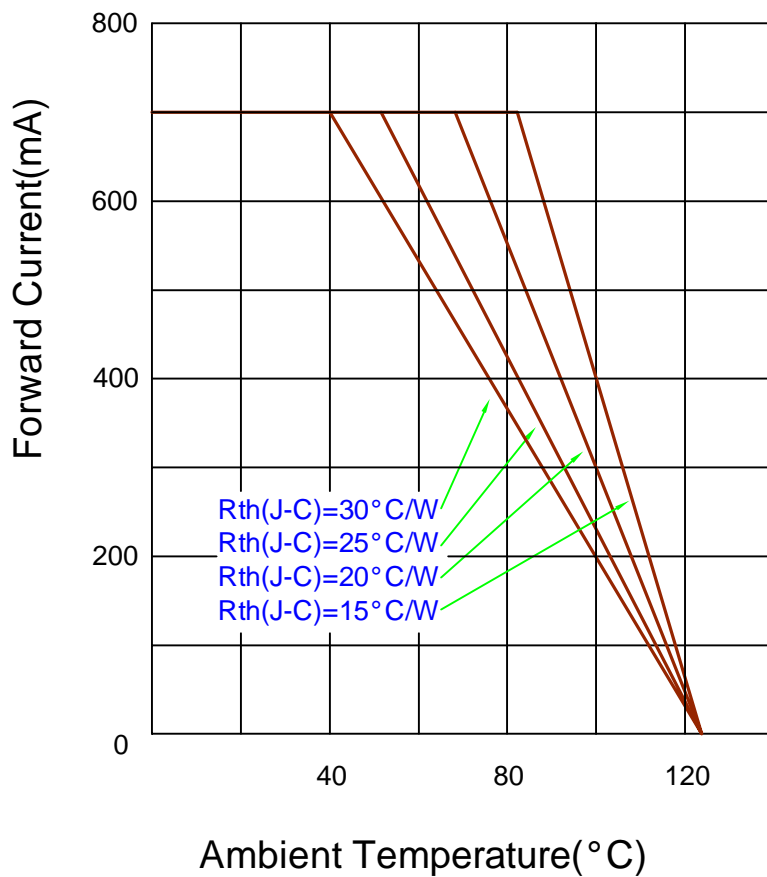



Fig.3 Forward current vs. Luminous Flux

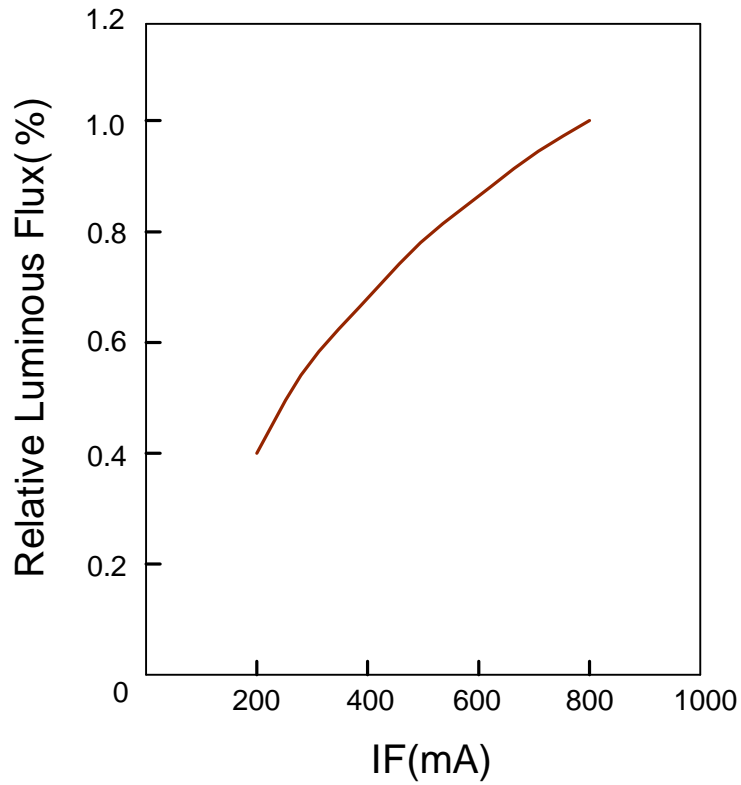

Fig.4 Junction Temperature vs. Forward Voltage

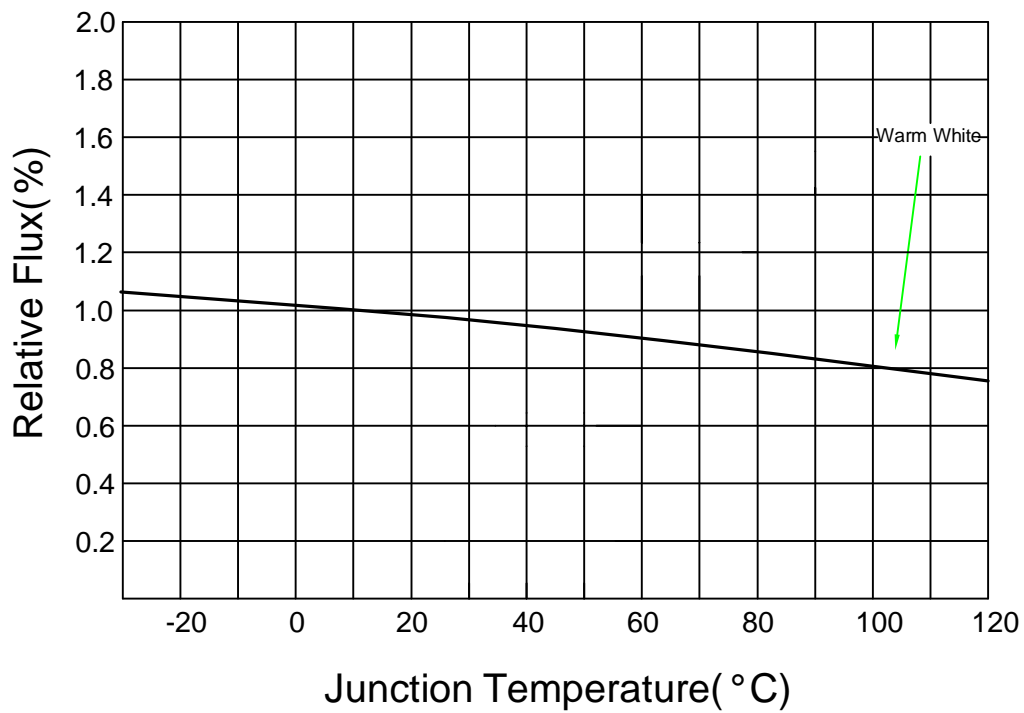

Fig.5 Luminous Spectrum( $T_a=25^\circ\text{C}$ )

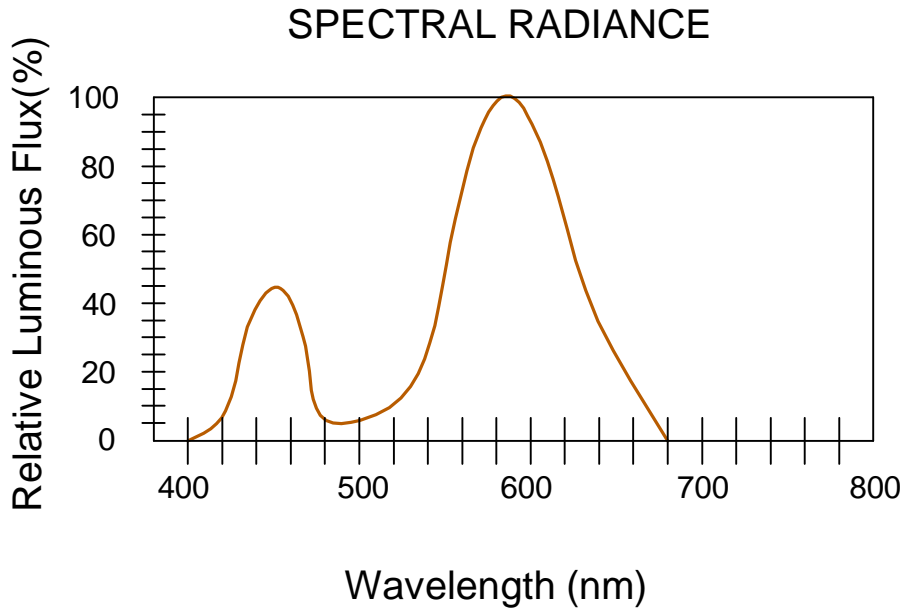
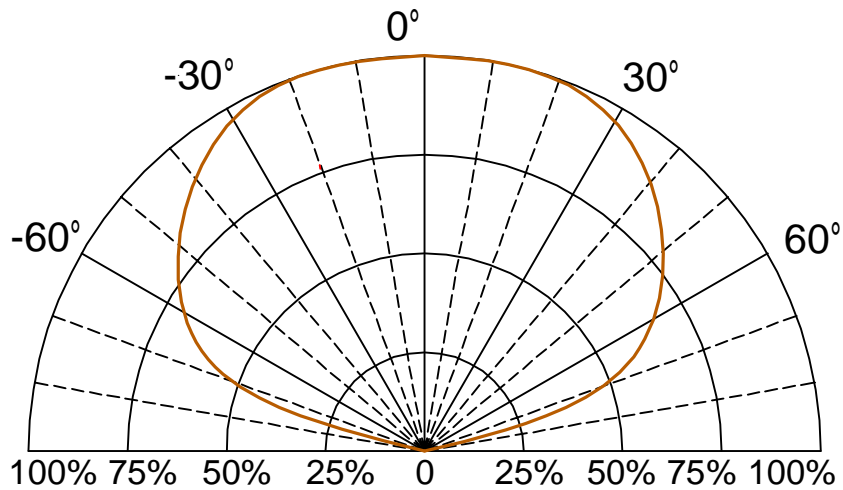

Fig.6 Directivity Radiation





PACKING SPECIFICATION

1. 34PCS / TUBE

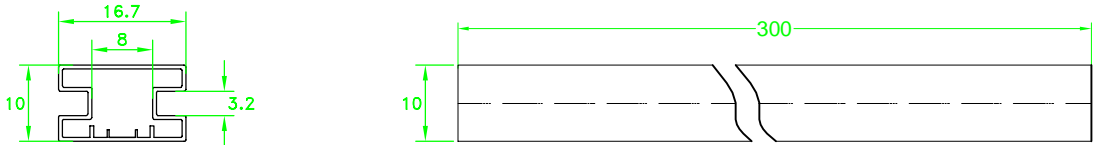

2. 66 TUBES / INNER BOX (11\*6)

SIZE : L X W X H 33.5cm X 19cm X 7.5cm

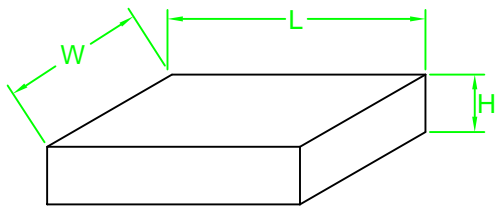

3. 12 INNER BOXES / CARTON

SIZE : L X W X H 58.5cm X 34cm X 34cm

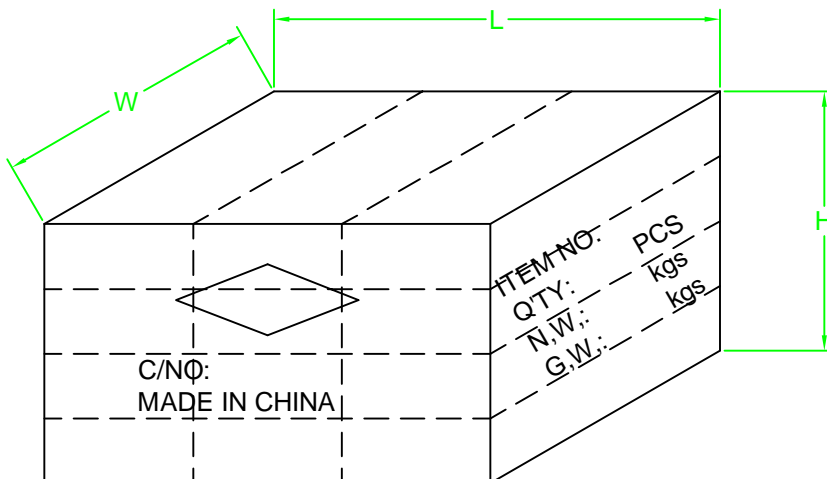

## Reliability Test

Item	Description	Stress Condition	Test Duration
RTOL	Room Temperature Operation Life	25° C, IF:max.DC (Note1)	1000 hours
WHT	Wet High Temperature	85° C/85%RH	1000 hours
TC	Temperature Cycling	-40/+110° C, 30min dwell,<5min trans.	200 cycles
TS	Thermal Shock	-40/+110° C, 20min dwell,<20min trans.	200 cycles
HTSL	High Temperature Storage Life	120° C	1000 hours
LTSL	Low Temperature Storage Life	-40° C	1000 hours
SHR	Solder Heat Resistance	260±5° C, 5secs	
MS	Mechanical Shock	1500G,0.5msec pulse, 5 shocks each 6 axis	
ND	Natural Drop	On concrete from 1.2m, 3xtimes	
RV	Random Vibration	6G RMS from 10 to 2KHz, 10mins/axis	
VVF	Variable Vibration Frequency	10-2000-10Hz, 20G 1 min, 1.5mm, 3timesx/axis	

Note :

1. Depending on the maximum derating curve.
2. Failure criteria:
  - Electrical failures
  - $V_F$  shife  $\geq 10\%$
  - $I_R > 50\mu A @ V_r = 5v$
  - Ligitek output Degradation
  - $\%I_v$  shift  $\geq 30\% @ 1000hrs$  or 200cycle
  - Visual failures
  - Broken or damaged package or lead
  - Dimension out of tolerance